

# engineering manual

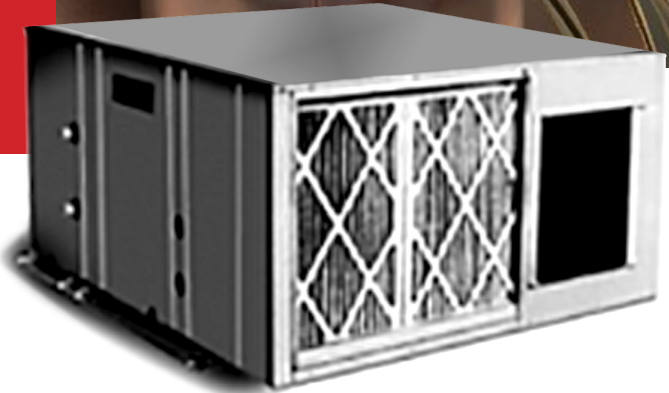

## Convertible

### Horizontal A/C's & Heat Pumps 2-15 Tons\*



- 2 to 15 Ton Capacities\*, High Static Capacity
- Ceiling Mounted, Unit Fits Completely Indoors
- Perfect for Office Spaces, Restaurants & Retail Stores
- Packaged & Split DX Air, Water/Glycol Cooled & Chilled Water Systems
- Fit Thru 30" Doors, Ideal for Retro Fit

*\* Up to 8 ton or Air Cooled*

*\* Up to 10 ton for Water Cooled and Glycol Cooled*

*\* Up to 15 ton for Chilled Water Systems*



Excellence In Ceiling Mounted AC and Environmental Control Systems  
800.625.7545 [www.Skil-air.com](http://www.Skil-air.com)

CPG-EM-CH-1001-11

**Skil-aire™**. We Hang Around All The Best Places.

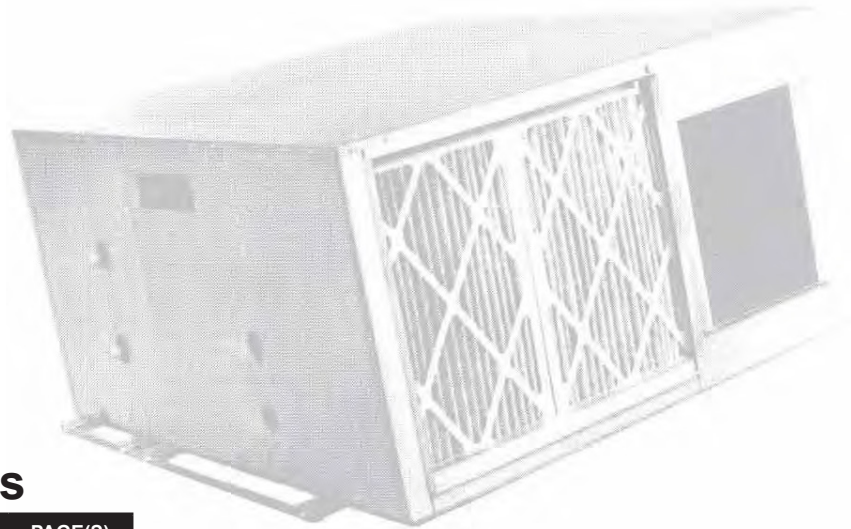

## Table of Contents

TOPIC	PAGE(S)
Table of Contents	2
Model Nomenclature	2
Convertible™ Comfort Series Overview	3
<b>Mechanical Data</b>	
Performance Data	4
Condenser Data	5
Connection Sizes	6
<b>Electrical Data</b>	
DX Air Cooled, Self-Contained Systems	8
DX - Water & Glycol, Self-Contained Systems	8
DX & Chilled Water Air Handling Units	9
Remote DX - Air Cooled Condensing Units	10
<b>Physical Data</b>	
Approximate Shipping Weights Table	10
<b>Guide Specifications</b>	
Standard Features	11-13
Optional Features	13-15
<b>Dimensional Data</b>	
PAA-( ), Air Cooled, Self-Contained	16
BAA DX Air Handling Units	17
CAA - Remote Outdoor Condensing Units	17
Chilled Water Air Handling Units	18
FU - Remote Outdoor Condensing Units	19
PWA-( ), Water Cooled, Self-Contained	20
PGA-( ), Glycol Cooled, Self-Contained	20
BWA DX Air Handling Units For Water Cooled Units	21
<b>Glycol Pump Packages &amp; Drycoolers</b>	
Glycol Pump Packages	22

## Model Nomenclature

### PWA-096-H4-ECX

Packaged - <b>P</b>	ECX - Economizer Coil
Evaporator Only - <b>B</b>	EXT - Extended Cabinet Option
Centrifugal Condenser - <b>C</b>	FU - Outdoor Propeller Fan Condensing Unit
Air Cooled - <b>A</b>	T - Triple Circuit
Chilled Water - <b>C</b>	NC - No Compressor
Water Cooled - <b>W</b>	1 - 208-230/1/60
Glycol Cooled - <b>G</b>	3 - 208-230/3/60
Comfort - <b>A</b>	4 - 460/3/60
Heat Pump - <b>H</b>	5 - 575/3/60
Outdoor Air - <b>O</b>	7 - 277/1/60
	H - Horizontal
	024 - Nominal 2.0 Ton
	036 - Nominal 3.0 Ton
	048 - Nominal 4.0 Ton
	060 - Nominal 5.0 Ton
	072 - Nominal 6.0 Ton
	096 - Nominal 8.0 Ton
	120 - Nominal 10.0 Ton
	144 - Nominal 12.0 Ton
	180 - Nominal 15.0 Ton

# Convertible™

Skil-aire™ Built to Last With Design Features That Assure Superior Performance and Dependability in Any Application.

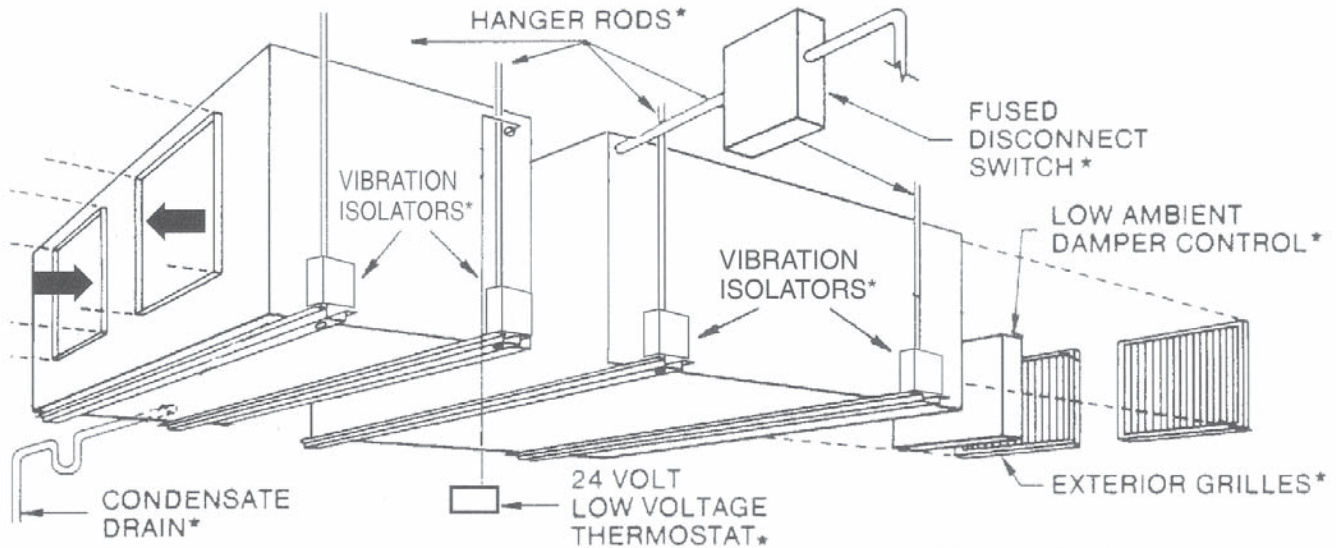

*\*Field installed by others.*

The **Skil-aire Convertible™**, packaged or split air conditioners and heat pumps have high external static pressures. These compact units fit through standard 30" doors and are field splittable, up to 150 equivalent feet, without losing the factory tested refrigerant\*

## Flexible Microprocessor Controls:



DigiSkil-100 & 200



MicroSkil-100 & 200

## IAQ Comfort:

- Steam Humidifier
- Electric, Hot Water, Steam or Heat Pump Heating
- High Efficiency Air Filtration



## Energy Saving Options:

- Air-Side Economizer/Free-Cooling
- ECX - Water/Glycol Side Economizer/Free-Cooling

## Head Pressure Control:

- Air Cooled - Choose from -17.8°C (0°F), -28.9°C (-20°F) and -34.4°C (-30°F) Low Ambient Options
- Water/Glycol Cooled - 2 and 3-way standard and high pressure regulating valve options



## High Static Belt-Drive Blowers:

- Ducted Systems Available with Up to 2.0" E.S.P.



## Capacity Modulation:

- Hot Gas Bypass

## Select Accessories:

- Condensate Pumps
- Non-Fused Disconnects
- Firestats
- Smoke Detectors
- Remote Water Detectors
- and more ...!

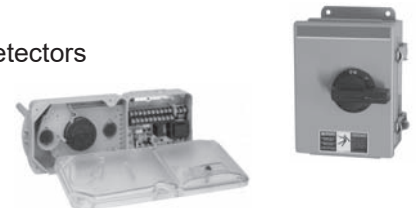

\*Note - with use of optional stub kit

# MECHANICAL DATA: Convertible™

Nominal Tons	2.0	3.0	4.0	5.0	6.0	8.0	10.0	12.0	15.0	
Model Size	024	036	048	060	072	096	120	144	180	
<b>DX - AIR COOLED @ 35°C (95°F) Entering Condenser Air</b>										
<b>26.7°C (80°F) DB, 50% RH</b>										
Total / Sensible	KW (MBH)	7.3 / 5.2 (24.8 / 17.8)	10.6 / 7.8 (36.3 / 26.6)	13.9 / 10.2 (47.4 / 34.7)	20.2 / 14.2 (68.9 / 48.5)	21.5 / 15.7 (73.5 / 53.6)	27.9 / 18.9 (95.4 / 64.5)	N/A		
<b>23.9°C (75°F) DB, 50% RH</b>										
Total / Sensible	KW (MBH)	6.6 / 5.1 (22.6 / 17.6)	9.9 / 7.7 (33.8 / 26.3)	12.9 / 10.1 (44.1 / 34.3)	17.2 / 13.3 (58.7 / 45.3)	20.0 / 15.6 (68.3 / 53.1)	25.9 / 18.7 (88.6 / 63.8)	N/A		
<b>AIR SOURCE HEAT PUMP HEATING CAPACITY @ 8.3°C (47°F) DB &amp; -8.3°C (17°F) DB</b>										
21.1°C (70°F) DB / Indoor Air	KW (MBH)	8.8 / 5.1 (30.0 / 17.4)	11.9 / 6.6 (40.7 / 22.5)	16.0 / 9.4 (54.7 / 32.1)	19.0 / 10.6 (65.0 / 36.2)	22.5 / 12.5 (76.8 / 42.6)	29.2 / 14.08 (99.7 / 48.05)	N/A		
EER/SEER		13.28	14.21	13.17	14.43	11.22	11.21	N/A		
<b>DX - WATER COOLED @ 29.4°C (85°F) Entering Condenser Water</b>										
<b>26.7°C (80°F) DB, 50% RH</b>										
Total / Sensible	KW (MBH)	7.7 / 5.5 (26.3 / 18.7)	11.0 / 7.6 (37.5 / 26.0)	15.0 / 10.7 (51.4 / 36.6)	19.1 / 13.4 (65.3 / 45.7)	23.0 / 16.5 (78.7 / 56.2)	30.7 / 21.3 (104.7 / 72.6)	38.6 / 26.8 (131.6 / 91.6)	N/A	
<b>23.9°C (75°F) DB, 50% RH</b>										
Total / Sensible	KW (MBH)	7.2 / 5.3 (24.4 / 18.0)	10.2 / 7.4 (35.0 / 25.2)	14.0 / 10.6 (47.9 / 36.3)	17.7 / 13.0 (60.6 / 44.1)	21.5 / 15.9 (73.2 / 54.5)	27.7 / 20.6 (94.4 / 70.3)	35.9 / 26.0 (122.4 / 88.6)	N/A	
EER/SEER		13.28	13.12	14.29	13.49	13.25	13.66	13.13	N/A	
<b>DX - GLYCOL COOLED @ 43.3°C (110°F), 40% Entering Ethylene Glycol</b>										
<b>26.7°C (80°F) DB, 50% RH</b>										
Total / Sensible	KW (MBH)	7.9 / 5.7 (26.8 / 19.5)	10.9 / 8.1 (37.2 / 27.7)	14.4 / 10.7 (49.1 / 36.4)	19.1 / 13.4 (65.3 / 45.7)	22.2 / 16.7 (75.7 / 57.1)	26.9 / 20.1 (91.7 / 68.6)	35.5 / 26.5 (121.3 / 90.5)	N/A	
<b>23.9°C (75°F) DB, 50% RH</b>										
Total / Sensible	KW (MBH)	7.0 / 5.5 (24.0 / 18.8)	9.8 / 7.9 (33.6 / 27.0)	13.0 / 10.4 (44.5 / 35.5)	17.7 / 13.1 (60.4 / 44.8)	20.0 / 16.4 (68.4 / 55.9)	24.3 / 19.7 (82.8 / 67.3)	32.2 / 25.0 (109.8 / 85.2)	N/A	
<b>CHILLED WATER SYSTEMS @ 7.2°C (45°F) Entering Water Temp.</b>										
<b>26.7°C (80°F) DB, 50% RH</b>										
Total / Sensible	KW (MBH)	7.7 / 5.7 (26.4 / 19.4)	11.5 / 8.4 (39.4 / 28.5)	14.2 / 10.6 (48.6 / 36.1)	18.1 / 13.5 (61.6 / 45.9)	23.9 / 17.4 (81.5 / 59.3)	30.2 / 21.7 (103.2 / 74.2)	39.9 / 29.9 (136.0 / 102.0)	46.9 / 35.2 (160.0 / 120.0)	64.2 / 58.0 (219.0 / 198.0)
<b>23.9°C (75°F) DB, 50% RH</b>										
Total / Sensible	KW (MBH)	6.2 / 5.2 (21.1 / 17.9)	9.1 / 7.7 (31.2 / 26.2)	11.4 / 9.8 (38.8 / 33.4)	14.4 / 12.4 (49.2 / 42.4)	19.1 / 16.0 (65.1 / 54.7)	24.0 / 20.0 (81.9 / 68.1)	30.5 / 26.7 (104.0 / 91.0)	39.0 / 35.2 (133.0 / 120.0)	47.5 / 43.7 (162.0 / 149.0)
Flow Rate	LPM (GPM)	15.1 (4)	26.5 (7)	28.4 (7.5)	37.9 (10)	45.4 (12)	68.1 (18)	113.6 (30)	136.3 (36)	155.2 (41)
Pressure Drop	kPa (FT W.G.)	7.5 (2.5)	21.2 (7.1)	6.6 (2.2)	11.7 (3.9)	12.0 (4)	22.7 (7.6)	25.1 (8.4)	34.7 (11.6)	43.9 (14.7)
Standard Valve		2-way, 150 psig - factory installed (3-way & High Pressure Valves are Optional)								

## AIR COOLED FEATURES

<b>Evaporator Airflow</b>										
Discharge	L/S (CFM)	377.5 (800)	566.3 (1,200)	755.0 (1,600)	943.8 (2,000)	1,132.6 (2,400)	1,132.6 (2,400)	1,887.6 (4,000)	2,265.1 (4,800)	2,548.3 (6,000)
	IN ESP	0.10	0.15	0.20	0.20	0.25	0.25	0.30	0.35	0.40
Fan Motor	HP	1/2	1/2	3/4	1	1 1/2	2	3	5	5
Fan Diameter	CM (IN)	24.4 X 17.8 (10 X 7)	30.5 X 22.9 (12 X 9)	30.5 X 22.9 (12 X 9)	38.1 X 22.9 (15 X 9)	38.1 X 22.9 (15 X 9)	38.1 X 22.9 (15 X 9)	38.1 X 22.9 (15 X 9)	38.1 X 22.9 (15 X 9)	38.1 X 22.9 (15 X 9)
<b>Evaporator Coil - Aluminum Fin, Copper Tube</b>										
Rows	NO	4	4	4	3	3	3	3	3	3
Face Area	M² (FT²)	0.2 (2.5)	0.4 (4.1)	0.4 (4.1)	0.8 (8.2)	0.8 (8.2)	0.8 (8.2)	0.8 (8.2)	0.8 (8.2)	0.8 (8.2)
Face Velocity	MPM (FPM)	97.5 (320)	89.3 (293)	118.9 (390)	74.4 (244)	89.3 (293)	89.3 (293)	149.0 (489)	178.3 (585)	223.0 (732)
<b>Air Filtration - @ 40% NBS Dust Spot</b>										
Nominal Size	CM IN(NO)	50.8x50.8x5.1 20x20x2(1)	35.6x63.5x5.1 14x25x2(2)	35.6x63.5x5.1 14x25x2(2)	40.6x63.5x5.1 16x25x2(3)	40.6x63.5x5.1 16x25x2(3)	40.6x63.5x5.1 16x25x2(3)	40.6x63.5x5.1 16x25x2(3)	40.6x63.5x5.1 16x25x2(3)	40.6x63.5x5.1 16x25x2(3)

## WATER COOLED FEATURES

<b>Evaporator Airflow</b>										
Discharge	L/S (CFM)	377.5 (800)	566.3 (1,200)	755.0 (1,600)	943.8 (2,000)	1,132.6 (2,400)	1,415.625 (3,000)	1,887.6 (4,000)	2,265.1 (4,800)	2,548.3 (6,000)
	IN ESP	0.10	0.15	0.20	0.20	0.25	0.25	0.30	0.35	0.40
Fan Motor	HP	1/2	1/2	3/4	1	1 1/2	2	3	5	5
Fan Diameter	CM (IN)	24.4 X 17.8 (10 X 7)	24.4 X 17.8 (10 X 7)	30.5 X 22.9 (12 X 9)	30.5 X 22.9 (12 X 9)	30.5 X 22.9 (12 X 9)	30.5 X 22.9 (12 X 9)	38.1 X 22.9 (15 X 9)	38.1 X 22.9 (15 X 9)	38.1 X 22.9 (15 X 9)

# MECHANICAL DATA: Convertible™

## WATER COOLED FEATURES CONTINUED

Nominal Tons	2.0	3.0	4.0	5.0	6.0	8.0	10.0	12.0	15.0	
Model Size	024	036	048	060	072	096	120	144	180	
<b>Evaporator Coil - Aluminum Fin, Copper Tube</b>										
Rows	NO	4	4	4	4	5	5	3	3	3
Face Area	M <sup>2</sup> (FT <sup>2</sup> )	0.2 (2.5)	0.2 (2.5)	0.4 (4.1)	0.4 (4.1)	0.5 (4.9)	0.5 (4.9)	0.8 (8.2)	0.8 (8.2)	0.8 (8.2)
Face Velocity	MPM (FPM)	97.5 (320)	146.25 (480)	118.9 (390)	149 (488)	149 (489)	186.5 (612)	149.0 (488)	178.3 (585)	223.0 (732)
<b>Air Filtration - @ 40% NBS Dust Spot</b>										
Nominal Size	CM IN(NO)	50.8x50.8x5.1 20x20x2(1)	50.8x50.8x5.1 20x20x2(1)	35.6x63.5x5.1 14x25x2(2)	35.6x63.5x5.1 14x25x2(2)	35.6x63.5x5.1 14x25x2(2)	35.6x63.5x5.1 14x25x2(2)	35.6x63.5x5.1 14x25x2(2)	40.6x63.5x5.1 16x25x2(3)	40.6x63.5x5.1 16x25x2(3)

## COMMON FEATURES

<b>Compressor - Heat Pump Duty Hermetic</b>										
(NO) HP	(1) 2.0	(1) 3.0	(1) 4.0	(1) 5.0	(2) 3.0	(2) 4.0	(2) 5.0	(3) 4.0	(3) 5.0	
<b>Heat (Duct Mounted) - includes evaporator motor heat, (Optional)</b>										
Capacity	MBH	18.9	37.8	55.5	55.5	55.5	55.5	75.5	75.5	75.5
	KW	5.0	10.0	15.0	15.0	15.0	15.0	20.0	20.0	20.0
Stages	NO	1	2	2	2	2	2	2	2	2
<b>Steam Canister Humidifier - (Optional)</b>										
Steam Canister	LBS/HR	5	5	10	10	15	15	15	15	15
<b>Connection Sizes - Copper</b>										
Condensate Drain	FPT CM (IN)	1.9 (3/4)	1.9 (3/4)	1.9 (3/4)	1.9 (3/4)	1.9 (3/4)	1.9 (3/4)	1.9 (3/4)	1.9 (3/4)	1.9 (3/4)

## Condenser Data

Nominal Tons	2.0	3.0	4.0	5.0	6.0	8.0	10.0	12.0	15.0	
Model Size	024	036	048	060	072	096	120	144	180	
<b>DX - AIR COOLED CONDENSER DATA</b>										
<b>Indoor / Outdoor, Centrifugal Air Cooled Condensing Unit Data - (PAA, PAH &amp; CAA models)</b>										
Discharge	L/S (CFM)	755.0 (1,600)	943.8 (2,000)	1,179.8 (2,500)	1,510.1 (3,200)	1,982.2 (4,200)	2,454.1 (5,200)	N/A		
	IN ESP	0	0	0	0	0	0			
Blower Motor	HP	3/4	1	1	1.5	2	3			
Fan Diameter	CM (IN)	30.5 X 22.9 (12 X 9)	38.1 X 22.9 (15 X 9)	38.1 X 22.9 (15 X 9)	38.1 X 38.1 (15 X 15)	38.1 X 38.1 (15 X 15)	38.1 X 38.1 (15 X 15)			
Blower Type		Centrifugal	Centrifugal	Centrifugal	Centrifugal	Centrifugal	Centrifugal			
Coil Face Area	FT sq.	4.2	6.7	6.7	9.3	9.3	9.3			
Rows	NO	4	4	4	4	5	5			
<b>Outdoor, Remote Air Cooled Condensing Unit - (FU models)</b>										
Discharge	L/S (CFM)	660.7 (1,400)	943.8 (2,000)	1,415.7 (3,000)	1,415.7 (3,000)	(2) 943.8 (2,000)	(2) 1,415.7 (3,000)	(2) 1,415.7 (3,000)	(3) 1,415.7 (3,000)	(3) 1,415.7 (3,000)
	IN ESP	0.0	0.0	0.0	0.0	0.0	0.0	0.0	0.0	0.0
Fan Motor	(NO) HP	(1) 1/6	(1) 1/6	(1) 1/4	(1) 1/6	(2) 1/6	(2) 1/4	(2) 1/6	(3) 1/4	(3) 1/6
Fan Type		Propeller	Propeller	Propeller	Propeller	Propeller	Propeller	Propeller	Propeller	Propeller
<b>DX - WATER COOLED CONDENSER DATA</b>										
<b>Water Cooled Condenser Data - (PWA models)</b>										
Flow @ 85F EWT	LPM (GPM)	23.1 (6.1)	33.3 (8.8)	47.7 (12.6)	54.1 (14.3)	66.6 (17.6)	87.1 (23.0)	108.3 (28.6)	N/A	
	Water Press. Drop (FT W.G.)	21.2 (7.1)	29.0 (9.7)	41.8 (14.0)	32.3 (10.8)	41.8 (14.0)	31.7 (10.6)	37.4 (12.5)		
Water Reg. Valve		2-Way, 150 psig - factory installed, (3-way & High Pressure Valves are Optional)								
<b>DX - GLYCOL COOLED CONDENSER DATA</b>										
<b>Glycol Cooled Condenser Data - @40% Ethylene Glycol (PGA models)</b>										
Flow @ 110F EGT	LPM (GPM)	26.9 (7.1)	40.1 (10.6)	52.2 (13.8)	67.4 (17.8)	80.3 (21.2)	99.6 (26.3)	134.8 (35.6)	N/A	
	Glycol Press. Drop (FT W.G.)	28.7 (9.6)	41.2 (13.8)	43.3 (14.5)	47.8 (16)	47.8 (16)	41.2 (13.8)	53.8 (18)		
Glycol Reg. Valve		2-Way, 150 psig - factory installed, (3-way & High Pressure Valves are Optional)								

<b>C o n n e c t i o n   S i z e s</b>										
Nominal Tons		2.0	3.0	4.0	5.0	6.0	8.0	10.0	12.0	16.0
Model Size		024	036	048	060	072	096	120	144	180
<b>DX - AIR COOLED REFRIGERANT (R410a) CONNECTION DATA</b>										
<small>(Note: Convertible dx evap-cond systems include as a standard refrigerant quick disconnects fittings. BAA or CAA only units require field sweat connection.)</small>										
<b>DX Air Handling Units - (BAA models only, condensing unit by others)</b>										
Liquid Line	OD CM (IN)	(1) 1.0 (3/8)	(1) 1.0 (3/8)	(1) 1.3 (1/2)	(1) 1.3 (1/2)	(2) 1.0 (3/8)	(2) 1.3 (1/2)	(2) 1.3 (1/2)	(3) 1.3 (1/2)	(3) 1.3 (1/2)
Suction Line	OD CM (IN)	(1) 1.6 (5/8)	(1) 2.2 (7/8)	(1) 2.2 (7/8)	(1) 2.2 (7/8)	(2) 2.2 (7/8)	(2) 2.2 (7/8)	(2) 2.2 (7/8)	(3) 2.2 (7/8)	(3) 2.2 (7/8)
<b>Outdoor, Propeller Remote Air Cooled Condensing Units - (FU models)</b>										
Liquid Line	OD CM (IN)	(1) 1.0 (3/8)	(1) 1.0 (3/8)	(1) 1.0 (3/8)	(1) 1.0 (3/8)	(1) 1.0 (3/8)	(1) 1.0 (3/8)	(1) 1.0 (3/8)	(1) 1.0 (3/8)	(1) 1.0 (3/8)
Suction Line	OD CM (IN)	(1) 1.9 (3/4)	(1) 1.9 (3/4)	(1) 2.2 (7/8)	(1) 2.2 (7/8)	(2) 1.9 (3/4)	(2) 2.2 (7/8)	(2) 2.2 (7/8)	(3) 2.2 (7/8)	(3) 2.2 (7/8)
<b>Indoor, Centrifugal Remote Air Cooled condensing Units - (CAA models only, dx air handling unit by others)</b>										
Liquid Line	OD CM (IN)	(1) 1.0 (3/8)	(1) 1.0 (3/8)	(1) 1.3 (1/2)	(1) 1.3 (1/2)	(2) 1.0 (3/8)	(2) 1.3 (1/2)	N/A		
Suction Line	OD CM (IN)	(1) 1.6 (5/8)	(1) 2.2 (7/8)	(1) 2.2 (7/8)	(1) 2.2 (7/8)	(2) 2.2 (7/8)	(2) 2.2 (7/8)	N/A		
<b>DX - WATER COOLED CONDENSER CONNECTION DATA</b>										
<b>Water Cooled Condenser Data - (PWA models)</b>										
Water IN/OUT	OD CM (IN)	1.6 (5/8)	1.9 (3/4)	2.2 (7/8)	2.2 (7/8)	2.5 (1)	3.2 (1 1/4)	3.2 (1 1/4)	Consult Factory	
<b>DX - GLYCOL COOLED CONDENSER CONNECTION DATA</b>										
<b>Glycol Cooled Condenser Data - @ 40% Ethylene Glycol (PGA models)</b>										
Glycol IN/OUT	OD CM (IN)	1.9 (3/4)	2.2 (7/8)	2.2 (7/8)	2.9 (1 1/8)	3.2 (1 1/4)	3.2 (1 1/4)	4.1 (1 5/8)	Consult Factory	
<b>CHILLED WATER SYSTEMS CONNECTION DATA</b>										
<b>Chilled Water Systems Data - (PCA models)</b>										
Chilled Water IN/OUT	OD CM (IN)	1.3 (1/2)	2.5 (1)	2.5 (1)	2.5 (1)	2.5 (1)	3.8 (1 1/2)	5.1 (2)	5.1 (2)	5.1 (2)

## Air Cooled, Self-Contained

(FLA = Full Load Amps / MCA = Min Circuit Amps / MFS = Max Fuse Size) \* see notes 1-4 below

HEAT	None, Heat Pump, Hot Water or Steam Heat (No Electric Heat)				None, Heat Pump, Hot Water or Steam Heat (No Electric Heat)				<b>ELECTRIC DUCT HEATER</b> *see note-2 (Requires Separate Power Supply)					
HUMIDIFICATION	None				Steam Canister Humidifier									
DX - AIR COOLED SELF-CONTAINED														
Power Supply	208/1/60	277/1/60	208/3/60	460/3/60	208/1/60	277/1/60	208/3/60	460/3/60	KW	NO. OF STAGES	208/1/60	277/1/60	208/3/60	460/3/60
<b>PAA &amp; PAH-024</b>									<b>FLA</b>					
FLA	20.2	18.5	13.4	6.4	27.6	24.6	20.8	10.1	<b>5 KW</b>	<b>1 STG</b>	20.8	18.1	13.9	6.3
MCA	23.8	21.2	15.6	7.4	31.2	27.3	23.0	11.1						
MFS	40	35	25	15	50	40	35	20						
<b>PAA &amp; PAH-036</b>									<b>10 KW</b>	<b>2 STG</b>	41.7	36.1	27.8	12.6
FLA	25.2	24	17.4	9.3	32.6	30.1	24.8	13.0						
MCA	29.9	27.8	20.3	10.9	37.3	33.9	27.7	14.6						
MFS	50	45	35	20	60	50	40	25	<b>15 KW</b>	<b>2 STG</b>	N/A	N/A	41.6	18.8
<b>PAA &amp; PAH-048</b>														
FLA	Consult Factory	Consult Factory	22.3	10.4	Consult Factory	Consult Factory	33.1	17.8						
MCA			26.1	12.1			40.9	19.5						
MFS			45	20			60	30.0						
<b>PAA &amp; PAH-060</b>									<b>15 KW</b>	<b>2 STG</b>	N/A	N/A	41.6	18.8
FLA	Consult Factory	Consult Factory	26.2	13.0	Consult Factory	Consult Factory	36.2	20.4						
MCA			30.6	15.1			45.4	22.6						
MFS			50	25			70	35						
<b>PAA &amp; PAH-072</b>									<b>15 KW</b>	<b>2 STG</b>	N/A	N/A	41.6	18.8
FLA	N/A	N/A	33.8	18.1	N/A	N/A	42.2	24.5						
MCA			36.7	19.7			50.9	26.1						
MFS			50	30			70.0	35						
<b>PAA &amp; PAH-096</b>									<b>15 KW</b>	<b>2 STG</b>	N/A	N/A	41.6	18.8
FLA	N/A	N/A	43.1	21.7	N/A	N/A	57.3	28.1						
MCA			46.7	23.5			60.9	29.9						
MFS			60	30			70	35						
									<b>20 KW</b>	<b>2 STG</b>	N/A	N/A	N/A	25.1
									<b>20 KW</b>	<b>2 STG</b>	N/A	N/A	N/A	25.1
									<b>20 KW</b>	<b>2 STG</b>	N/A	N/A	N/A	25.1

**\* Notes:**

- 1) 277V available via field installed step-down transformer.
- 2) Factory installed electric heat is available within the Optional Convertible™ Extended Cabinet Configuration ("EXT"). Please consult your local representative for details.
- 3) The above unit electrical data is reflective of the standard performance data and standard options as shown on pages 4 & 5.
- 4) Due to a policy of continuous improvement, Skil-aire reserves the right to change specifications without notice and without incurring any liability. Always consult equipment name plate for exact electrical requirements.

# TYPICAL ELECTRICAL DATA : Convertible™

## Water & Glycol Cooled, Self-Contained

(FLA = Full Load Amps / MCA = Min Circuit Amps / MFS = Max Fuse Size) \* see notes 1-4 below

HEAT	None, Heat Pump, Hot Water or Steam Heat (No Electric Heat)				None, Heat Pump, Hot Water or Steam Heat (No Electric Heat)				<b>ELECTRIC DUCT HEATER</b> *see note-2 (Requires Separate Power Supply)					
HUMIDIFICATION	None				Steam Canister Humidifier									
DX - WATER & GLYCOL COOLED, SELF-CONTAINED														
Power Supply	208/1/60	277/1/60	208/3/60	460/3/60	208/1/60	277/1/60	208/3/60	460/3/60	KW	NO. OF STAGES	208/1/60	277/1/60	208/3/60	460/3/60
<b>PWA &amp; PGA-024</b>														
FLA	16.7	14.3	10.4	4.9	24.1	20.4	17.8	8.6	<b>5 KW</b>	<b>1 STG</b>	20.8	18.1	13.9	6.3
MCA	20.3	17.0	12.6	5.9	27.7	23.1	20.0	9.6						
MFS	35	30.0	25	15	45	35	30	15						
<b>PWA &amp; PGA-036</b>														
FLA	21.0	18.6	13.4	7.3	28.4	24.7	20.8	11.0	<b>10 KW</b>	<b>2 STG</b>	41.7	36.1	27.8	12.6
MCA	25.7	22.4	16.3	8.9	33.1	28.5	23.7	12.6						
MFS	45	40	30	20	60	45	40	20						
<b>PWA &amp; PGA-048</b>														
FLA	Consult Factory	Consult Factory	18.3	8.4	Consult Factory	Consult Factory	33.1	12.1	<b>15 KW</b>	<b>2 STG</b>	N/A	N/A	41.6	18.8
MCA			22.1	10.1			36.9	13.8						
MFS			40	20			60	25						
<b>PWA &amp; PGA-060</b>														
FLA	Consult Factory	Consult Factory	21.4	10.6	Consult Factory	Consult Factory	36.2	18.0	<b>15 KW</b>	<b>2 STG</b>	N/A	N/A	41.6	18.8
MCA			25.8	12.8			40.6	20.2						
MFS			45	25			60.0	30						
<b>PWA &amp; PGA-072</b>														
FLA	N/A	N/A	28.0	15.2	N/A	N/A	42.2	21.6	<b>15 KW</b>	<b>2 STG</b>	N/A	N/A	41.6	18.8
MCA			30.9	16.8			45.1	23.2						
MFS			45	25			60.0	30						
<b>PWA &amp; PGA-096</b>														
FLA	N/A	N/A	36.4	16.7	N/A	N/A	50.6	23.1	<b>15 KW</b>	<b>2 STG</b>	N/A	N/A	41.6	18.8
MCA			40.2	18.4			54.4	24.8						
MFS			60	30			70.0	35						
<b>PWA &amp; PGA-120</b>														
FLA	N/A	N/A	42.4	21.0	N/A	N/A	56.6	27.4	<b>20 KW</b>	<b>2 STG</b>	N/A	N/A	N/A	25.1
MCA			46.8	23.2			61.0	29.6						
MFS			70.0	35.0			80.0	40.0						
<b>20 KW 2 STG N/A N/A N/A 25.1</b>														
<b>20 KW 2 STG N/A N/A N/A 25.1</b>														

**\* Notes:**

- 1) 277V available via field installed step-down transformer.
- 2) Factory installed electric heat is available within the Optional Convertible™ Extended Cabinet Configuration ("EXT"). Please consult your local representative for details.
- 3) The above unit electrical data is reflective of the standard performance data and standard options as shown on pages 4 & 5.
- 4) Due to a policy of continuous improvement, Skil-air reserves the right to change specifications without notice and without incurring any liability. Always consult equipment name plate for exact electrical requirements.



# TYPICAL ELECTRICAL DATA : Convertible™

## DX and Chilled Water Air Handling Units

(FLA = Full Load Amps / MCA = Min Circuit Amps / MFS = Max Fuse Size) \* see notes 1-4 below

HEAT	None, Heat Pump, Hot Water or Steam Heat (No Electric Heat)				None, Heat Pump, Hot Water or Steam Heat (No Electric Heat)				<b>ELECTRIC DUCT HEATER</b> *see note-2 (Requires Separate Power Supply)					
HUMIDIFICATION	None				Steam Canister Humidifier									
DX - SPLIT AIR HANDLING UNITS ONLY & CHILLED WATER SYSTEMS														
Power Supply	208/1/60	277/1/60	208/3/60	460/3/60	208/1/60	277/1/60	208/3/60	460/3/60	KW	NO. OF STAGES	208/1/60	277/1/60	208/3/60	460/3/60
<b>BAA &amp; PCA-024</b>									<b>FLA</b>					
FLA	2.4	3.6	1.8	0.9	9.8	9.7	9.2	4.6	<b>5 KW</b>	<b>1 STG</b>	20.8	18.1	13.9	6.3
MCA	3.0	4.5	2.3	1.1	12.3	12.1	11.5	5.8						
MFS	15.0	15.0	15.0	15.0	15.0	15.0	15.0	15.0						
<b>BAA &amp; PCA-036</b>														
FLA	2.4	3.6	1.8	0.9	9.8	9.7	9.2	4.6	<b>10 KW</b>	<b>2 STG</b>	41.7	36.1	27.8	12.6
MCA	3.0	4.5	2.3	1.1	12.3	12.1	11.5	5.8						
MFS	15.0	15.0	15.0	15.0	15.0	15.0	15.0	15.0						
<b>BAA &amp; PCA-048</b>														
FLA	Consult Factory	Consult Factory	3.0	1.5	Consult Factory	Consult Factory	17.8	8.9	<b>15 KW</b>	<b>2 STG</b>	N/A	N/A	41.6	18.8
MCA			3.8	1.9			22.3	11.1						
MFS			15.0	15.0			25.0	15.0						
<b>BAA &amp; PCA-060</b>														
FLA	Consult Factory	Consult Factory	4.0	2.0	Consult Factory	Consult Factory	18.8	9.4	<b>15 KW</b>	<b>2 STG</b>	N/A	N/A	41.6	18.8
MCA			5.0	2.5			23.5	11.8						
MFS			15.0	15.0			25.0	15.0						
<b>BAA &amp; PCA-072</b>														
FLA	N/A	N/A	4.8	2.4	N/A	N/A	19.0	8.8	<b>15 KW</b>	<b>2 STG</b>	N/A	N/A	41.6	18.8
MCA			6.0	3.0			23.8	11.0						
MFS			15.0	15.0			25.0	15.0						
<b>BAA &amp; PCA-096</b>														
FLA	N/A	N/A	5.8	2.9	N/A	N/A	20.0	9.3	<b>15 KW</b>	<b>2 STG</b>	N/A	N/A	41.6	18.8
MCA			7.3	3.6			25.0	11.6						
MFS			15.0	15.0			30.0	15.0						
<b>BAA &amp; PCA-120</b>														
FLA	N/A	N/A	7.6	3.8	N/A	N/A	21.8	10.2	<b>20 KW</b>	<b>2 STG</b>	N/A	N/A	N/A	25.1
MCA			9.5	4.8			27.3	12.8						
MFS			20.0	15.0			35.0	15.0						
<b>PCA-144</b>														
FLA	N/A	N/A	13.7	7.1	N/A	N/A	27.9	13.5	<b>20 KW</b>	<b>2 STG</b>	N/A	N/A	N/A	25.1
MCA			17.1	8.9			34.9	16.9						
MFS			30	15			40	20						
<b>PCA-180</b>														
FLA	N/A	N/A	13.7	7.1	N/A	N/A	27.9	13.5	<b>20 KW</b>	<b>2 STG</b>	N/A	N/A	N/A	25.1
MCA			17.1	8.9			34.9	16.9						
MFS			30	15			40	20						

**\* Notes:**

- 1) 277V available via field installed step-down transformer.
- 2) Factory installed electric heat is available within the Optional Convertible™ Extended Cabinet Configuration ("EXT"). Please consult your local representative for details.
- 3) The above unit electrical data is reflective of the standard performance data and standard options as shown on pages 4 & 5.
- 4) Due to a policy of continuous improvement, Skil-aire reserves the right to change specifications without notice and without incurring any liability. Always consult equipment name plate for exact electrical requirements.

# TYPICAL ELECTRICAL DATA : Convertible™

## Air Cooled, Remote Condensing Units

(FLA = Full Load Amps / MCA = Min Circuit Amps / MFS = Max Fuse Size) \* see notes 1-3 below

CAA - Indoor Centrifugal Blower Air Cooled Remote Condensing Units				
Power Supply	208/1/60	277/1/60	208/3/60	460/3/60
<b>CAA-024</b>				
FLA	17.8	14.9	11.6	5.5
MCA	21.4	17.6	13.8	6.5
MFS	40.0	30.0	25.0	15.0
<b>CAA-036</b>				
FLA	22.8	20.4	15.6	8.4
MCA	27.5	24.2	18.5	10.0
MFS	50.0	40.0	35.0	20.0
<b>CAA-048</b>				
FLA	Consult Factory	Consult Factory	19.3	8.9
MCA			23.1	10.6
MFS			40.0	20.0
<b>CAA-060</b>				
FLA	Consult Factory	Consult Factory	22.2	11.0
MCA			26.6	13.2
MFS			45.0	25.0
<b>CAA-072</b>				
FLA	N/A	N/A	29.0	15.7
MCA			31.9	17.3
MFS			45.0	25.0
<b>CAA-096</b>				
FLA	N/A	N/A	36.4	16.7
MCA			40.2	18.4
MFS			60	30

FU - Outdoor Propeller Fan Air Cooled Remote Condensing Units				
Power Supply	208/1/60	277/1/60	208/3/60	460/3/60
<b>024 / FU</b>				
FLA	11.9	Consult Factory	N/A	N/A
MCA	14.6			
MFS	20			
<b>036 / FU</b>				
FLA	12.7	Consult Factory	11.6	5.8
MCA	15.5		14.2	7.1
MFS	20		20	15
<b>048 / FU</b>				
FLA	Consult Factory	Consult Factory	14.7	7.2
MCA			17.9	8.8
MFS			30	15
<b>060 / FU</b>				
FLA	Consult Factory	Consult Factory	20.5	8.7
MCA			25.1	10.7
MFS			40	15

Qty. one FU condensing unit is provided per circuit:

- PAA/PAH-072 units are provided with qty. 2 x 036-FUunits
- PAA/PAH-096 units are provided with qty. 2 x 048-FUunits
- PAA/PAH-120 units are provided with qty. 2 x 060-FUunits
- PAA/PAH-144 units are provided with qty. 3 x 048-FUunits
- PAA/PAH-180 units are provided with qty. 3 x 060-FUunits

\* Notes:

- 1) 277V available via field installed step-down transformer.
- 2) The above unit electrical data is reflective of the standard performance data and standard options as shown on pages 4 & 5.
- 3) Due to a policy of continuous improvement, Skil-air reserves the right to change specifications without notice and without incurring any liability. Always consult equipment name plate for exact electrical requirements.

## Approximate Ship Weights kg. (lbs.)

UNIT SIZE	MODEL TYPE							
	PAA & PAH			FU	PWA/H & PGA/H			PCA
	Evap (BAA)	Cond (CAA)	Packaged		Evap (BAA)	Cond (CWA)	Packaged	
024	72.6 (160)	226.8 (500)	299.4 (660)	84.8 (187)	63.5 (140)	198.7 (438)	262.2 (578)	102.1 (225)
036	104.4 (230)	260.8 (575)	365.1 (805)	99.3 (219)	68.0 (150)	209.1 (461)	277.1 (611)	138.3 (305)
048	104.3 (230)	272.1 (600)	376.5 (830)	89.8 (198)	77.1 (170)	230.0 (507)	307.1 (677)	163.3 (360)
060	158.8 (350)	589.7 (1300)	748.4 (1650)	109.8 (242)	83.5 (184)	243.6 (537)	327.1 (721)	170.1 (375)
072	163.3 (360)	607.8 (1340)	771.1 (1700)	99.3 (219) x 2	89.8 (198)	259.5 (572)	349.3 (770)	172.4 (380)
096	167.8 (370)	621.4 (1370)	791.5 (1745)	89.8 (198) x 2	99.8 (220)	282.1 (622)	381.9 (842)	176.9 (390)
120	N/A			109.8 (242) x 2	285.7 (630)	572.0 (1261)	857.7 (1891)	272.2 (600)
144				99.3 (219) x 3	N/A			317.5 (700)
180				109.8 (242) x 3	N/A			317.5 (700)

## 1.0 GENERAL

### 1.1 SUMMARY

These specifications describe requirements for an air conditioning system. The system shall be designed to maintain temperature and relative humidity conditions within the specified room. The manufacturer shall design and furnish all equipment to be fully compatible with the heat dissipation requirements of the site.

The system shall be manufactured by Skil-aire, a division of Tithe Corporation, in Baltimore, Maryland U.S.A. The system shall be approved and labeled by Underwriters Laboratories, Inc. (UL). The system shall be New York City MEA (MEA-386-90-E) and Chicago Code Approved.

### 1.2 DESIGN REQUIREMENTS

The comfort control system shall be a Skil-aire factory assembled Convertible™ model ceiling mounted system. The evaporator section shall be specifically designed for above ceiling installation, unless specified otherwise.

The system shall have a total cooling capacity of \_\_\_\_\_ BTUH and a sensible cooling capacity of \_\_\_\_\_ BTUH based on an entering air temperature of \_\_\_\_\_ °F DB and \_\_\_\_\_ °F WB. The unit shall be supplied with \_\_\_\_\_ volt, \_\_\_\_\_ phase, \_\_\_\_\_ Hz electrical service. The system model number shall be \_\_\_\_\_.

## 2.0 PRODUCTS

### 2.1 STANDARD FEATURES / ALL SYSTEMS

#### 2.1.1 CABINET

The cabinet and access panels shall be fabricated from sturdy heavy gauge galvanized steel. The panels shall be lined with 2 lb. density thermal/acoustical insulation for whisper quiet operation. The evaporator cabinet shall be equipped with a full condensate pan constructed of stainless steel. Large removable side panels shall provide ease of installation, service and maintenance on the system.

#### 2.1.2 BLOWER ASSEMBLIES

Blowers shall be belt driven double-inlet, dynamically balanced with multiple forward curved blades mounted on a solid steel keyed shaft. A heavy-duty V-belt fan drive (sized for 200% of motor nameplate horsepower) with adjustable cast iron pulleys keyed and secured to the blower shaft shall be provided for adjusting fan speed to system requirements.

#### 2.1.3 MOTOR ASSEMBLIES

All fan motors shall be permanently mounted, 1750 or 3450 RPM, with overload protection. Motors shall have permanently lubricated ball bearings and be resiliently mounted to an adjustable motor frame. Motor pulleys shall be cast iron, keyed, with variable pitch design to allow for field adjustment of specific airflow and static requirements.

#### 2.1.4 AIR PATTERN - DUCTED

Evaporators and indoor air cooled remote condensing unit sections shall be designed for ducted air distribution. Air inlet and outlet connections shall include factory provided turned-out duct flanges for ease of field duct connection.

#### 2.1.5 FILTERS

The system shall be provided with 2" extended surface pleated disposable type filters rated for a 40% average dust-spot efficiency. The filters shall be removable without shutting down the system.

#### 2.1.6 ELECTRICAL CIRCUITS

The system shall be provided with a factory installed main electrical enclosure per NEC code requirements. A low voltage transformer with integral protection shall be provided to supply 24 VAC to the control circuit. The 24 volt control circuit terminal strips shall be clearly labeled for thermostat wiring and interlock. The fan motor(s), compressor, humidifier and electric heater (if applicable) shall each have their own contactor. A float switch shall be provided in the evaporator section to sense a clogged condensate drain and shall shut the unit down to prevent water damage.

#### **Self-Contained Systems:** (single point power)

Self-Contained systems shall be designed for single point main power connection.

#### **Split DX Systems:** (separate power)

Split systems shall require separate main power supplies to the evaporator and condensing unit sections. The evaporator and condensing unit sections shall be electrically interlocked by a field wired 24 volt control signal.

### 2.2 DIRECT EXPANSION SYSTEM COMPONENTS

#### 2.2.1 EVAPORATOR COILS

The evaporator coil shall be quality construction of seamless drawn rifled copper tube, mechanically bonded to tempered aluminum fins with galvanized coil end plates. The coil shall have \_\_\_\_\_ sq. ft. face area, \_\_\_\_\_ rows deep. The coil shall be factory pressure tested and the refrigeration system sealed prior to shipment. A stainless steel drain pan shall be provided to cover the entire coil area.

## 2.2.2 COMPRESSORS

Each compressor is heat pump duty. Each compressor shall be mounted on vibration isolators and located in the condensing section out of the evaporator air stream. Each compressor shall be complete with reversible positive oil pump, charging and service ports, internal spring isolation, and discharge gas vibration eliminator.

## 2.2.3 REFRIGERATION CIRCUIT

Each refrigeration circuit shall be pre-piped with type "L" refrigerant copper tubing. Each refrigeration system shall include, but not be limited to: expansion valve with external equalizer and rapid bleed-through capacity. Features shall include filter dryer, sight glass, pressure fittings and high pressure/low pressure safety cutouts.

## 2.3 CHILLED WATER SYSTEMS

### 2.3.1 CHILLED WATER AIR HANDLERS (Models PCA)

The system shall be a chilled water air handling unit. The chilled water coil shall be of quality construction of seam- less drawn rifled copper tube, mechanically bonded to tempered aluminum fins with galvanized coil end plates. The coil shall be factory pressure tested. The coil shall have \_\_\_\_\_ sq. ft. face area, \_\_\_\_\_ rows deep. A stainless steel drain pan shall be provided to cover the entire coil area. The coil shall be controlled by a factory installed 2-way chilled water control valve. The coil shall be designed to distribute water into the entire coil face area. The coil shall be supplied with \_\_\_\_\_ °F entering water temperature with a \_\_\_\_\_ °F temperature rise. The coil shall require \_\_\_\_\_ GPM of chilled water and the pressure drop shall not exceed \_\_\_\_\_ Ft. w.g.

## 2.4 STANDARD FEATURES - INDIVIDUAL SYSTEMS

### 2.4.1 AIR COOLED SYSTEMS

#### 2.4.1.1 AIR COOLED, SELF-CONTAINED (Models PAA)

The system shall be self-contained with integral factory installed air cooled condensing unit. The condensing unit shall be a belt driven, centrifugal blower type. The condenser coil shall be constructed of copper tubes and aluminum fins. The condensing unit shall be sized for full heat of rejection at 35°C (95°F) ambient and be capable of operation to \_\_\_\_\_ °F low ambient air temperature. The condensing unit shall be factory tested, charged with refrigerant, sealed and be capable of being connected to the evaporator section directly when the units are close coupled or using pre-charged refrigerant lines sets when the condensing unit is mounted remote from the evaporator.

Models PAA-024/096 shall ship from the factory as one-piece unit as standard. Models PAA-024/096 may ship

split from the factory for field rigging purposes.

*(Note: PAA-024/096 packaged units are designed to be field converted to split systems; refrigerant quick disconnects and Stub-Kit Option for field provided interconnecting piping available.)*

#### 2.4.1.2 OUTDOOR, REMOTE PROPELLER FAN, AIR COOLED CONDENSING UNIT (FU models)

The remote air cooled condensing unit shall be an outdoor mounted direct drive, propeller fan type arranged for vertical air discharge. The condensing unit shall be sized for full heat of rejection at 35°C (95°F) ambient and be capable of operation to \_\_\_\_\_ °F. The condenser coil shall be constructed of copper tube and aluminum fins. The coil shall be factory tested, and refrigeration system sealed prior to shipment. The condenser fan motor shall have permanently lubricated bearings and inherent internal overload protection.

#### 2.4.1.3 DX - AIR HANDLING UNIT ONLY (Models BAA)

The system shall be a split DX - Air Handling Unit designed for field connection to a remote condensing unit. The air handling unit shall include, but not be limited to: evaporator coil, stainless steel condensate drain pan, adjustable belt-driven blower, blower motor, thermal expansion valve with external equalizer, refrigerant service valves, refrigerant sight glass / moisture indicator, filter drier, refrigerant quick connect fittings, 24 volt terminal connection and 2" filters.

*(Note: When purchased without a Skil-air™ condensing unit, BAA systems ship from the factory with a dry nitrogen holding charge. When purchased with a Skil-air™ condensing unit, BAA systems ship from the factory with a full refrigerant operating charge.)*

#### 2.4.1.4 INDOOR (OPTIONAL OUTDOOR) REMOTE CENTRIFUGAL BLOWER AIR COOLED CONDENSING UNIT (Models CAA)

The system shall be an indoor (*outdoor - optional*) remote air cooled condensing unit designed for field connection to a dx air handling unit. The condensing unit shall be a belt driven, centrifugal blower type. The condensing unit shall be sized for full heat of rejection at 35°C (95°F) ambient and be capable of operation to \_\_\_\_\_ °F low ambient air temperature. The condensing unit shall be factory tested, charged with refrigerant, sealed and be capable of being connected to the evaporator section directly when the units are close coupled or using pre-charged refrigerant lines sets when the condensing unit is mounted remote from the evaporator.

*(Note-1: When purchased without a Skil-air™ evaporator unit, CAA systems ship from the factory with a dry nitrogen holding charge. When purchased with a Skil-air™ evaporator unit, CAA systems ship from the factory with a full refrigerant operating charge.)*

*Note-2: CAA condensing units can be configured for outdoor installation via outdoor weather protection kit option.)*

## 2.4.2 WATER COOLED CONDENSERS

(PWA models) **\*\*Water Valve Optional\*\***

Water cooled systems shall have a coaxial, counter flow liquid condenser with adjustable 2-way water regulating valve per circuit to maintain head pressure with condenser water flow. The unit shall require \_\_\_\_\_ GPM of \_\_\_\_\_ °F water and have a maximum pressure drop of \_\_\_\_\_ Ft. w.g.

## 2.4.3 GLYCOL COOLED CONDENSER

(PGA models)

Glycol cooled systems shall have a coaxial, counter flow liquid condenser with adjustable 2-way glycol regulating valve to maintain head pressure with condenser glycol flow. The unit shall require \_\_\_\_\_ GPM of \_\_\_\_\_ °F glycol and have a maximum pressure drop of \_\_\_\_\_ Ft. w.g.

## 2.4.4 DRY COOLER & SIMPLEX PUMP PACKAGE

(FCPP models)

The drycooler shall be complete with field mounted expansion tank and aquastat to control fan motor operation. The coil shall have seamless copper tubes bonded to aluminum fins for high transfer efficiency. The motor(s) shall have permanently lubricated bearings with inherent overload protection on 1 Phase motors and three coil overloads on 3 Phase motors.

The pump package shall include controls to operate the drycooler and the pump. The pump package shall be enclosed in a weatherproof housing. The pump shall be rated for \_\_\_\_\_ GPM at \_\_\_\_\_ Ft. of head, and operate on \_\_\_\_\_ volt, \_\_\_\_\_ PH, 60Hz.

## 2.5 OPTIONS

### 2.5.1 AIR COOLED CONDENSER - LOW AMBIENT CONTROL

#### 2.5.1.1 -17.8°C (0°F) AMBIENT - FAN CYCLING (FU Propeller Fan Models)

Condenser fan cycling controls shall be factory provided for field installation to allow for low ambient condenser operation to -17.8°C (0°F) minimum air temperature.

#### 2.5.1.2 -17.8°C (0°F) - LOW AMBIENT DAMPER-NOT AVAILABLE

(PAA, CAA Centrifugal Blower Condensing Units)

A low ambient inlet damper shall be provided for the condenser section to allow operation to -17.8°C (0°F) minimum air temperature. The damper shall include an actuator that is controlled directly by the condensed liquid line pressure. The damper shall be field mounted with all control piping furnished by the installer.

#### 2.5.1.3 -28.9°C (-20°F) VARIABLE SPEED FAN (FU Propeller Fan Models)

Variable speed head pressure controls shall be factory provided for field installation to allow for low ambient condenser

operation to -28.9°C (-20°F) minimum air temperature.

### 2.5.1.4 -34.4°C (-30°F) FLOODED CONDENSER (PAA, CAA & FU Models)

A flooded condenser system shall be provided to allow for low ambient condenser operation to -34.4°C (-30°F). The flooded system shall include a factory installed liquid refrigerant receiver and head pressure control valve.

### 2.5.2 WATER / GLYCOL COOLED - HEAD PRESSURE CONTROL VALVES

#### 2.5.2.1 3-WAY WATER / GLYCOL HEAD PRESSURE CONTROL VALVES (PWA & PGA Models)

Each refrigerant circuit's head pressure shall be controlled by a factory provided 3-way water/glycol regulating valve rated for 150 psig w.w.p.

#### 2.5.2.2 350 PSI HIGH PRESSURE - WATER/GLYCOL HEAD PRESSURE CONTROL VALVES

Each refrigerant circuit's head pressure shall be controlled by a factory provided high pressure rated \_\_\_\_\_ (2 or 3) -way water/glycol regulating valve rated for 350 psig w.w.p.

### 2.5.3 CONTROL OPTIONS

#### 2.5.3.1 DigiSkil-100™: Remote Wall Mounted, Non-Programmable Digital Thermostat

A DigiSkil-100™ model remote wall mounted single stage heat / cool non-programmable thermostat with digital display shall be factory provided for field installation. The thermostat shall include FAN AUTO-ON and COOL-OFF- HEAT selector switches.

#### 2.5.3.2 DigiSkil-200™: 7-Day Programmable Wall Mounted Digital Heat / Cool Thermostat

A DigiSkil-200™ model remote wall mounted deluxe 7-day programmable heat pump ready thermostat with digital display shall be factory provided for field installation. The thermostat shall include FAN AUTO-ON, COOL-OFF-HEAT-EM (emergency heat), SET and PROG/MAN selector switches.

#### 2.5.3.3 MicroSkil-100™: Microprocessor Temperature Humidity Controller with Alarms

The system shall be provided with a MicroSkil-100™ model Microprocessor based Temperature and Humidity controller with Alarms. Centered in the remote wall mounted controller shall be a graphic LCD display with characters to show the operating mode, time, set points and actual readings. The temperature and humidity sensors shall be internal to the remote display. The controller shall be capable of three different set points: normal, temporary and night per day, 7 days per week.

# GUIDE SPECIFICATIONS: Convertible™

The controller shall include the following visual and audible alarm indications (if applicable):

- High and Low Temperature
- High and Low Humidity
- Dirty Filter
- Sensor Failure
- Common Alarm Failure

The controller shall include the following system operations (if applicable):

- Unit Operational Status Indication - Cooling, Heating, Humidifying, Dehumidifying (if applicable)
- Fan - continuous or on demand
- Auto-restart upon power loss
- Remote stop/start connection
- Short cycle protection
- Cold start time delay
- Heat pump operation with aux. heat

## 2.5.3.4 MicroSkil-200™, Advanced Microprocessor Temperature & Humidity Controller with Alarms

The system shall be provided with a MicroSkil-200™ advanced microprocessor based temperature and humidity controller with alarms.

### Select Features/Benefits:

- 4x20 Character Liquid Crystal Alpha-numerical Display
- User Configurable
- Run-Time Hours
- Current Unit Mode Status
- Alarm Status
- Digital & Analog Inputs /Outputs
- Temperature Anticipation
- Remote Stop / Start Contact
- Summary Alarm Contact
- Automatic or Manual (selectable) Restart After Power Loss
- Sequential Load After Restart
- Recovery Delay
- Compressor Short Cycle Timers
- Cold Start Time Delay
- Security Password Access
- Self-Diagnostics
- Service Mode

### Unit Status Display

The control system shall display current unit functions and room status (if applicable):

- Current Dry Bulb Temp Set Point
- Current Relative Humidity Set Point
- System ON/OFF
- Cooling
- Heating
- Humidifying
- Dehumidifying - (Available with Satellite™ Series)
- Reheating - (Available with Satellite™ Series)
- Actual Room DB Temperature
- Actual Room Relative Humidity

### Alarm Conditions:

Alarm conditions activate an audible and visual indicator plus close a summary alarm dry contact connection. The control system shall alert to the following alarm conditions (if applicable):

- High Temperature
- Low Temperature
- High Humidity
- Low Humidity
- High Head Press
- Loss of Air Flow
- Loss of Power
- Dirty Filter
- Smoke Detection
- Firestat
- Leak Detection
- Sensor Failure
- Summary Failure

### Digital & Analog Control Inputs / Outputs:

The control system shall be capable of both digital (ON/OFF) and analog (proportional integral, PI) input and output control.

### Select Options:

- Multi-Unit Sequencing (Optional)
- BMS Communications (Optional)

### RS 485 Serial Port Connection: (Optional)

An RS 485 Serial Port Connection shall be provided for remote communications to BSM and/or Modem.

## 2.5.4 HEAT OPTIONS

### 2.5.4.1 ELECTRIC DUCT HEATER

(Field Installed)

The electric heat shall be a field installed duct heater with nichrome open wire elements, contactors and limit controls. The electric heater shall be UL approved. The electric heat shall have a capacity of \_\_\_\_\_ BTUH and a KW rating of \_\_\_\_\_ KW.

*(Note: Factory installed electric heat is available within the Optional Convertible™ Extended Cabinet Configuration "EXT". Please consult your local representative for details.)*

### 2.5.4.2 STEAM HEAT

(Requires Extended Cabinet for 2-8 Ton Units)

The steam heat coil shall have copper tubes and aluminum fins with capacity of \_\_\_\_\_ BTUH with \_\_\_\_\_ Ft. w.g. steam. The system shall be factory pre-piped with a 2-way steam control valve. Steam Heat coils are field installed. (They can be FACTORY installed on 2-8 ton units with the purchase of the extended cabinet option.)

### 2.5.4.3 HOT WATER HEAT

(Field Installed Hot Water Heat Coil Box & Valve)

A hot water heating coil box and valve shall be provided for field installation to the evaporator air inlet. The hot water heating coil shall have copper tubes and aluminum fins with a capacity of \_\_\_\_\_ BTUH when supplied with \_\_\_\_\_ °F entering water temperature, \_\_\_\_\_ GPM at \_\_\_\_\_ Ft. w.g. A factory provided 2-way hot water control valve shall be provided for field installation.

## 2.5.4.4 HEAT PUMPOPTION

(PAH, PWH & PGH models)

The system shall include a factory installed heat pump heating cycle including reversing valve, automatic defrost cycle (if appl.) and remote wall mounted temperature controller with auxiliary heating control capability. The heat pump mode heating capacity shall be \_\_\_\_\_ BTU/HR.

## 2.5.5 STEAM GENERATING HUMIDIFIER

The humidification system shall be an electrode canister type, complete with fill valve, drain valve, adjustable humidity output, and automatic flush cycle. The humidifier shall have a steam output capacity of \_\_\_\_\_ lbs/hr.

## 2.5.6 CONDENSATE PUMP

A condensate pump shall be factory provided for field installation. The condensate pump shall have the capacity of \_\_\_\_\_ GPH at \_\_\_\_\_ Ft. of head. The condensate pump shall be complete with integral float switch, pump and motor assembly, check valve and reservoir.

## 2.5.7 HOT GAS BYPASS

(DX Systems)

Each refrigerant circuit shall be provided with a hot gas bypass system for evaporator freeze-protection and capacity modulation during low load conditions.

## 2.5.8 VARIABLE AIR VOLUME (VAV) OPTION KIT

The system shall be designed for evaporator supply air control for application with a variable air volume (VAV) system. The shall incorporate Skil-aire's VAV Option Kit which shall include, but not be limited to:

- Variable Frequency Drive - factory installed
- Static Pressure Sensor / Transducer - field installed
- MicroSkil-2015/2015A, Advanced Microprocessor Controller w/ Supply Air Control Algorithm
- Circuit 1: Modulating (0-10 Vdc) Hot Gas Bypass
- Circuit 2: Standard Hot Gas Bypass

## 2.5.9 MAIN POWER NON-FUSED DISCONNECT

A main power non-fused disconnect shall be factory provided for field installation.

## 2.5.10 FIRESTAT

A firestat shall be factory provided. The firestat shall immediately shut down the environmental control system when activated. The firestat shall be mounted with sensing element in the return air duct, and wired by the installer to unit control panel.

## 2.5.11 SMOKE DETECTOR

A duct mounted type smoke detector shall be factory provided. The smoke detector shall immediately shut down the environmental control system when activated. The smoke detector shall be mounted in the return air duct by the installer and wired to the unit control panel.

## 2.5.12 AIR SIDE ECONOMIZER

(All Model Types)

The system shall be provided with an Air-Side Economizer to include factory provided and field installed air side economizer mixing box and controls per the following sequence of control:

On a call for cooling by the indoor space thermostat, the indoor fan and the economizer shall be energized. The outdoor air control shall determine whether the outdoor air is suitable for "free/economizer-cooling". If the outdoor air is suitable, mechanical cooling shall be locked out by the outdoor enthalpy control. The motor actuator shall be energized, operating the outdoor air and the return air dampers. The motor actuator shall be regulated by the mixed air sensor to maintain proper discharge air temperature.

When outdoor air is not suitable for "free/economizer-cooling", the Economizer shall be locked out and the outdoor air damper shall maintain minimum position while the indoor fan is operating. Upon unit shutdown or power loss, the spring return motor actuator shall close the outdoor air damper.

The Economizer shall be automatically locked out during the heat mode (if applicable).

The Air Side Economizer shall include: prewired modulating spring return motor actuator, compressor lockout, minimum position potentiometer, outdoor air control (enthalpy), mixed air sensor, multi-tap transformer and damper linkage.

The Air-Side Economizer and Controls shall ship separately from the unit for field installation.

*(Note: Refer to supplemental Air Side Economizer dimensional data for more information.)*

## 2.5.13 ECX - ECONOMIZER / FREE-COOLINGCYCLE

(Models PAA/PWA/PGA-ECX)

The system shall be provided with an auxiliary Skil-aire™ ECX economizer cooling coil with a factory mounted 3-way control valve. The ECX coil shall be capable of providing rated sensible capacity without compressor operation when entering water/glycol fluid temperatures are 7.2°C (45°F) or below.

*(Note: ECX option includes cabinet extension for 2-8 ton systems "EXT", external filter rack for 10-15 ton systems and upgraded fan motor (if required). Consult your local sales representative for details.)*

## 2.5.14 REFRIGERANT STUB KITS

(Split DX Systems)

Each refrigerant circuit shall be factory provided with refrigerant stub kits for ease of field refrigerant piping installation. Each stub kit shall include a pair of male and female Suction & Liquid Line refrigerant quick connect couplings matching the couplings factory installed to each

## PAA & PAH-024/096 (Self-Contained Air Cooled)

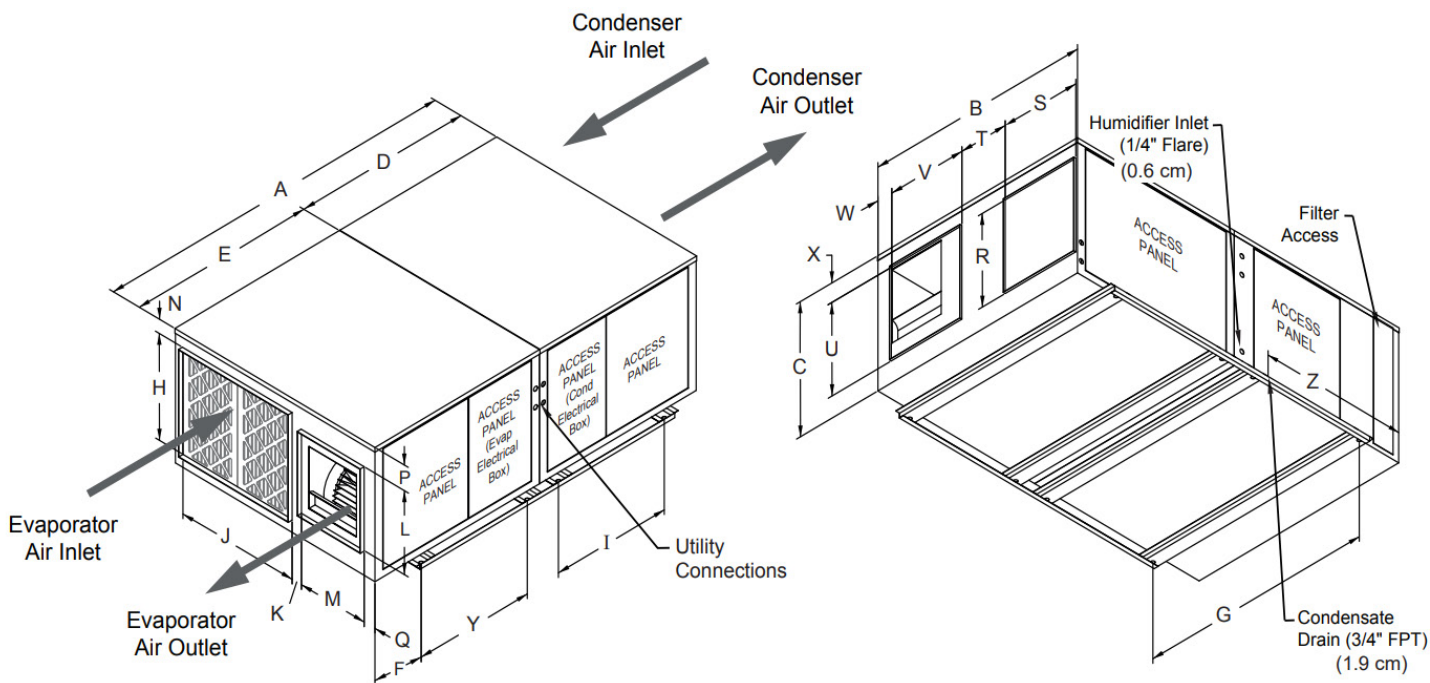

PAA / PAH-( ) MODEL SIZE	DIMENSIONS cm (inches)												
	A	B	C	D	E	F	G	H	I	J	K	L	M
024	149.9 (59)	109.5 (43 1/8)	55.9 (22)	87.6 (34 1/2)	62.2 (24 1/2)	14.3 (5 5/8)	113.7 (44 3/4)	45.7 (18)	68.9 (27 1/8)	50.8 (20)	7.0 (2 3/4)	35.6 (14)	30.5 (12)
	N	P	Q	R	S	T	U	V	W	X	Y	Z	
	3.2 (1 1/4)	5.7 (2 1/4)	14.6 (5 3/4)	40.6 (16)	40.6 (16)	14.0 (5 1/2)	40.6 (16)	40.6 (16)	14.0 (5 1/2)	4.8 (1 7/8)	42.5 (16 3/4)	61.0 (24)	

036 & 048	A	B	C	D	E	F	G	H	I	J	K	L	M
		174.0 (68 1/2)	130.2 (51 1/4)	73.7 (29)	102.2 (40 1/4)	71.8 (28 1/4)	18.7 (7 3/8)	133.7 (52 5/8)	58.4 (23)	68.9 (27 1/8)	71.1 (28)	6.4 (2 1/2)	45.7 (18)
N	P	Q	R	S	T	U	V	W	X	Y	Z		
	8.3 (3 1/4)	14.3 (5 5/8)	7.3 (2 7/8)	50.8 (20)	45.7 (18)	28.6 (11 1/4)	50.8 (20)	45.7 (18)	8.9 (3 1/2)	12.4 (4 7/8)	47.6 (18 3/4)	63.5 (25)	

060, 072 & 096	A	B	C	D	E	F	G	H	I	J	K	L	M
		227.3 (89 1/2)	177.8 (70)	73.7 (29)	139.7 (55)	87.6 (34 1/2)	19.1 (7 1/2)	181.6 (71 1/2)	63.5 (25)	108.6 (42 3/4)	116.8 (46)	6.4 (2 1/2)	50.8 (20)
N	P	Q	R	S	T	U	V	W	X	Y	Z		
	3.2 (1 1/4)	5.1 (2)	4.4 (1 3/4)	61.0 (24)	76.2 (30)	31.1 (12 1/4)	61.0 (24)	61.0 (24)	8.3 (3 1/4)	5.1 (2)	62.9 (24 3/4)	52.1 (20 1/2)	

### Notes:

- 1) All units ship from the factory as a packaged, one-piece unit.
- 2) If required, systems can be shipped from the factory split for rigging into the building. This option includes installed stub kits to prevent the loss of the refrigerant charge.



# UNIT DIMENSIONS: Convertible™

## BAA-024/180

(DX Split Air Handlers)

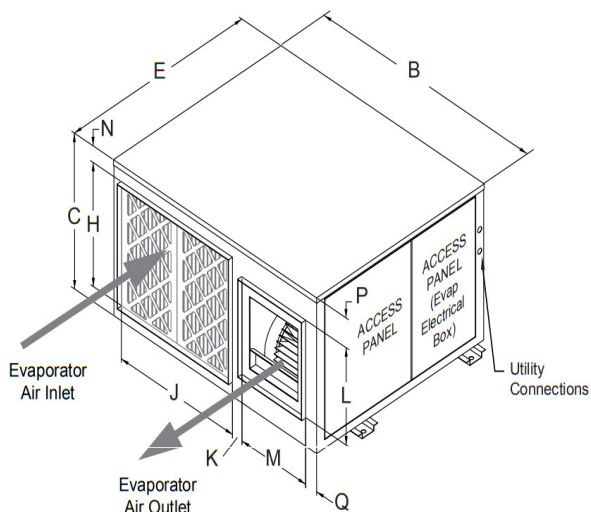

FRONT / RIGHT / TOP

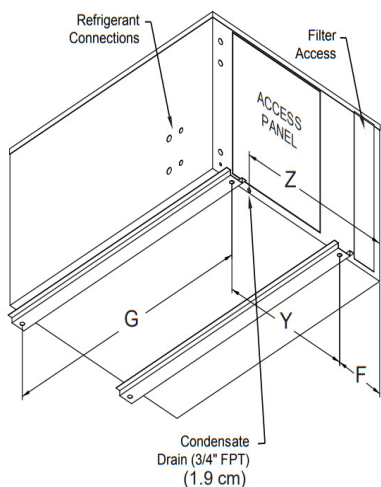

REAR / LEFT / BOTTOM

BAA & PCA (-) MODEL SIZE	DIMENSIONS cm (inches)							
	A	C	E	F	G	H	J	K
024	109.5 (43 1/8)	55.9 (22)	62.2 (24 1/2)	14.3 (5 5/8)	113.7 (44 3/4)	45.7 (18)	50.8 (20)	7.0 (2 3/4)
	L	M	N	P	Q	Y	Z	
	35.6 (14)	30.5 (12)	3.2 (1 1/4)	5.7 (2 1/4)	14.6 (5 3/4)	42.5 (16 3/4)	61.0 (24)	

036 & 048	B	C	E	F	G	H	J	K
	130.2 (51 1/4)	73.7 (29)	71.8 (28 1/4)	18.7 (7 3/8)	133.7 (52 5/8)	58.4 (23)	71.1 (28)	6.4 (2 1/2)
L	M	N	P	Q	Y	Z		
	45.7 (18)	40.6 (16)	8.3 (3 1/4)	14.3 (5 5/8)	7.3 (2 7/8)	47.6 (18 3/4)	63.5 (25)	

060, 072, 096, 120, 144 & 180	B	C	E	F	G	H	J	K
	177.8 (70)	73.7 (29)	87.6 (34 1/2)	19.1 (7 1/2)	181.6 (71 1/2)	63.5 (25)	116.8 (46)	6.4 (2 1/2)
L	M	N	P	Q	Y	Z		
	50.8 (20)	45.7 (18)	3.2 (1 1/4)	5.1 (2)	4.4 (1 3/4)	62.9 (24 3/4)	52.1 (20 1/2)	

## CAA-024/096

(Remote Centrifugal Blower, Indoor/Outdoor Air Cooled Condensing Units)

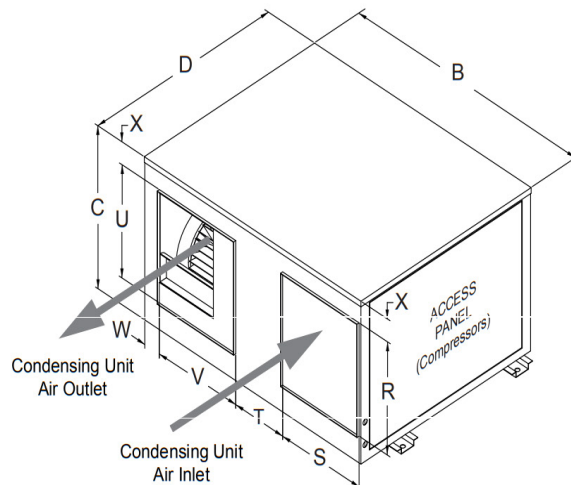

FRONT / RIGHT / TOP

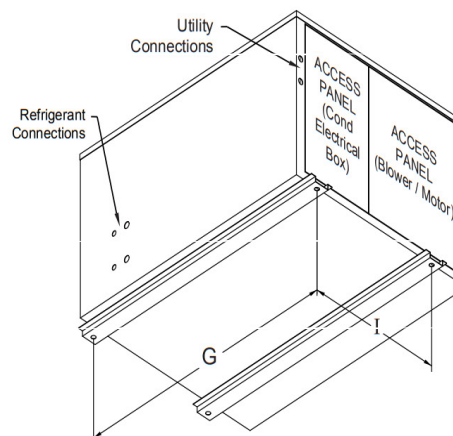

REAR / LEFT / BOTTOM

CAA (-) MODEL SIZE	DIMENSIONS cm (inches)					
	B	C	D	G	I	R
024	109.5 (43 1/8)	55.9 (22)	87.6 (34 1/2)	113.7 (44 3/4)	68.9 (27 1/8)	40.6 (16 0/1)
	S	T	U	V	W	X
	40.6 (16 0/1)	14.0 (5 1/2)	40.6 (16 0/1)	40.6 (16 0/1)	14.0 (5 1/2)	4.8 (1 7/8)

036 & 048	B	C	D	G	I	R
	130.2 (51 1/4)	73.7 (29)	102.2 (40 1/4)	133.7 (52 5/8)	68.9 (27 1/8)	50.8 (20)
S	T	U	V	W	X	
	45.7 (18)	28.6 (11 1/4)	50.8 (20)	45.7 (18)	8.9 (3 1/2)	12.4 (4 7/8)

060, 072 & 096	B	C	D	G	I	R
	177.8 (70)	73.7 (29)	139.7 (55)	181.6 (71 1/2)	108.6 (42 3/4)	61.0 (24)
S	T	U	V	W	X	
	76.2 (30)	31.1 (12 1/4)	61.0 (24)	61.0 (24)	8.3 (3 1/4)	5.1 (2)

## PCA-024/180 (Chilled Water Air Handlers)

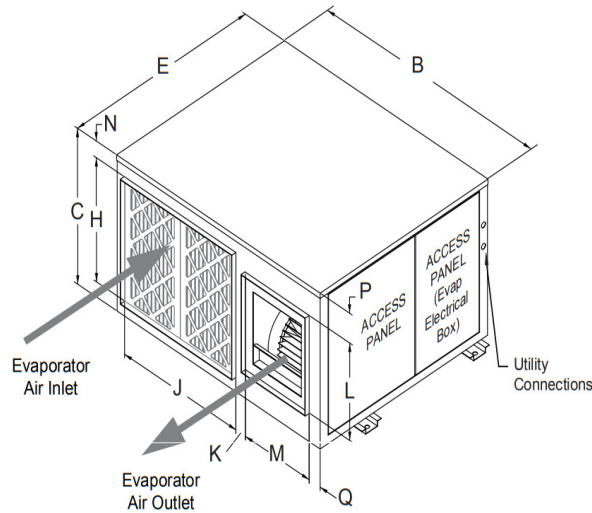

FRONT / RIGHT / TOP

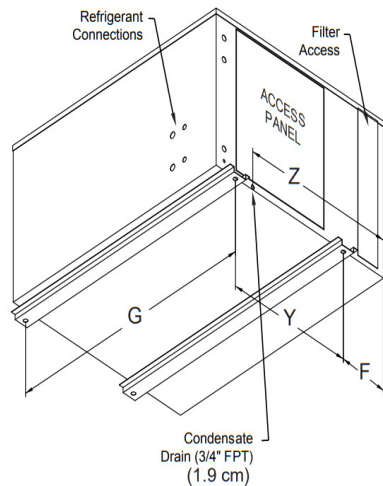

REAR / LEFT / BOTTOM

BAA & PCA-() MODEL SIZE	DIMENSIONS cm (inches)							
	A	C	E	F	G	H	J	K
024 & 036	109.5 (43 1/8)	55.9 (22)	62.2 (24 1/2)	14.3 (5 5/8)	113.7 (44 3/4)	45.7 (18)	50.8 (20)	7.0 (2 3/4)
	L	M	N	P	Q	Y	Z	
	35.6 (14)	30.5 (12)	3.2 (1 1/4)	5.7 (2 1/4)	14.6 (5 3/4)	42.5 (16 3/4)	61.0 (24)	

048, 060, 072 & 096	B	C	E	F	G	H	J	K
	130.2 (51 1/4)	73.7 (29)	71.8 (28 1/4)	18.7 (7 3/8)	133.7 (52 5/8)	58.4 (23)	71.1 (28)	6.4 (2 1/2)
L	M	N	P	Q	Y	Z		
45.7 (18)	40.6 (16)	8.3 (3 1/4)	14.3 (5 5/8)	7.3 (2 7/8)	47.6 (18 3/4)	63.5 (25)		

120, 144, 180	B	C	E	F	G	H	J	K
	177.8 (70)	73.7 (29)	87.6 (34 1/2)	19.1 (7 1/2)	181.6 (71 1/2)	63.5 (25)	116.8 (46)	6.4 (2 1/2)
L	M	N	P	Q	Y	Z		
50.8 (20)	45.7 (18)	3.2 (1 1/4)	5.1 (2)	4.4 (1 3/4)	62.9 (24 3/4)	52.1 (20 1/2)		

## 024/180-FU

(Remote Propeller Fan,  
Outdoor Air Cooled Condensing Units)

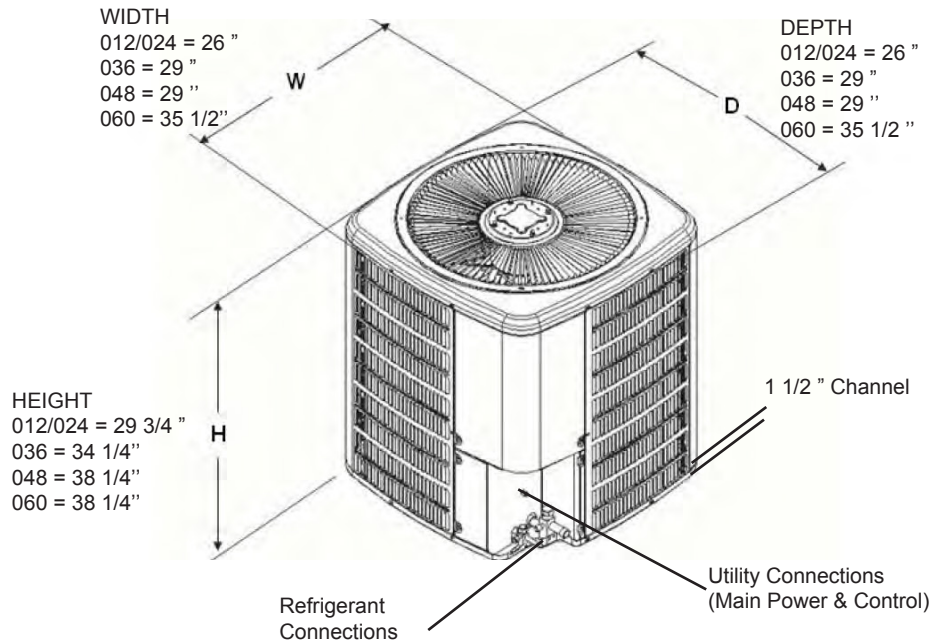

**Note:**

Qty. one FU condensing unit is provided per circuit:

- PAA/PAH-072 units are provided with qty. 2 x 036-FU units
- PAA/PAH-096 units are provided with qty. 2 x 048-FU units
- PAA/PAH-120 units are provided with qty. 2 x 060-FU units
- PAA/PAH-144 units may use qty. 3 x 048 or 2 x 072-FU units
- PAA/PAH-180 units may use qty. 3 x 060 or 2 x 096-FU units

## Recommended Refrigerant (R410a) Piping Line Sizing (Compressor(s) located with Condensing Unit Section)

Size	Compressors	Suction Line				Liquid Line	
		Evap lower than Condensing Unit (max lift)					
		Up to 100 Ft	Over 100 Ft	Upto 100 Ft	Over 100 Ft	Upto 100 Ft	Over 100 Ft
<b>2 Ton</b>	(1) 2T Comp	3/4	3/4	3/4	7/8	3/8	3/8
<b>3 Ton</b>	(1) 3T Comp	3/4	7/8	7/8	1-1/8	3/8	3/8
<b>4 Ton</b>	(1) 4T Comp	7/8	7/8	1-1/8	1-1/8	3/8	1/2
<b>5 Ton</b>	(1) 5T Comp	7/8	1-1/8	1-1/8	1-3/8	1/2	5/8
<b>6 Ton</b>	(2) 3T Comp	(2) 3/4	(2) 7/8	(2) 7/8	(2) 1-1/8	(2) 3/8	(2) 3/8
<b>8 Ton</b>	(2) 4T Comp	(2) 7/8	(2) 7/8	(2) 1-1/8	(2) 1-1/8	(2) 3/8	(2) 1/2
<b>10 Ton</b>	(2) 5T Comp	(2) 7/8	(2) 1-1/8	(2) 1-1/8	(2) 1-3/8	(2) 1/2	(2) 5/8
<b>12 Ton</b>	(2) 6T Comp	(2) 7/8	(2) 7/8	(2) 1-1/8	(2) 1-1/8	(2) 3/8	(2) 1/2
<b>15 Ton</b>	(2) 7.5T Comp	(2) 7/8	(2) 1-1/8	(2) 1-1/8	(2) 1-3/8	(2) 1/2	(2) 5/8

**Note:** Distances based on total calculated equivalent refrigerant piping length.

## PWA & PGA-024/120

(Self-Contained Water / Glycol Cooled)

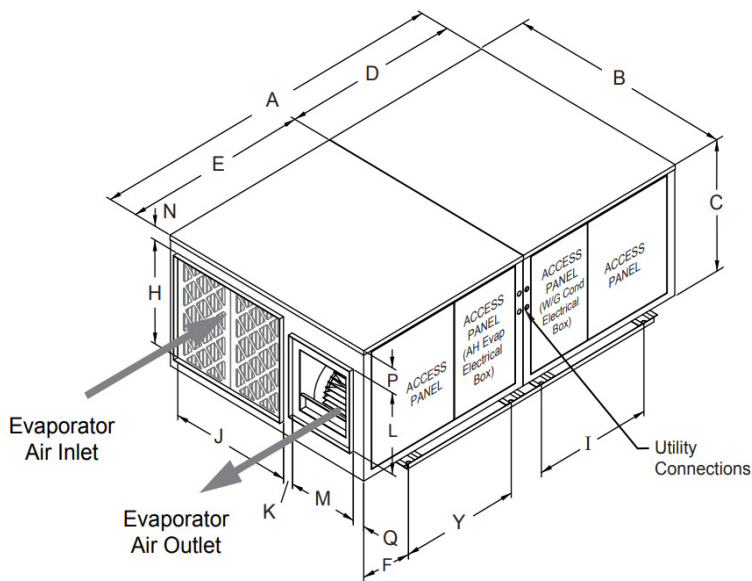

FRONT / RIGHT / TOP

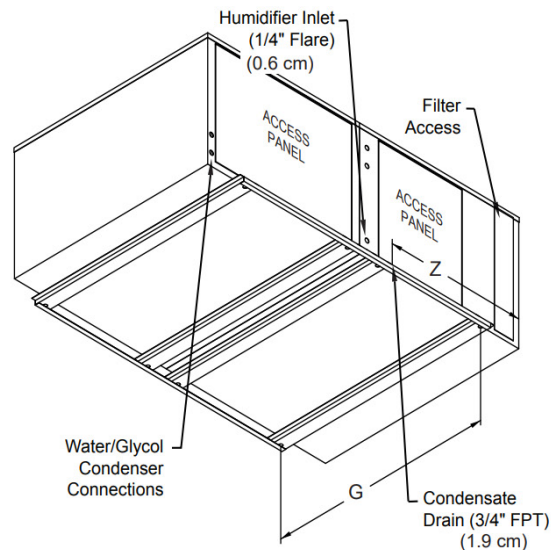

REAR / LEFT / BOTTOM

PWA/PGA-() MODEL SIZE	DIMENSIONS cm (inches)								
	A	B	C	D	E	F	G	H	I
024 & 036	149.9 (59)	109.5 (43 1/8)	55.9 (22)	87.6 (34 1/2)	62.2 (24 1/2)	14.3 (5 5/8)	113.7 (44 3/4)	45.7 (18)	68.9 (27 1/8)
	J	K	L	M	N	P	Q	Y	Z
	50.8 (20)	7.0 (2 3/4)	35.6 (14)	30.5 (12)	3.2 (1 1/4)	5.7 (2 1/4)	14.6 (5 3/4)	42.5 (16 3/4)	61.0 (24)
048, 060, 072 & 096	174.0 (68 1/2)	130.2 (51 1/4)	73.7 (29)	102.2 (40 1/4)	71.8 (28 1/4)	18.7 (7 3/8)	133.7 (52 5/8)	58.4 (23)	68.9 (27 1/8)
	J	K	L	M	N	P	Q	Y	Z
	71.1 (28)	6.4 (2 1/2)	45.7 (18)	40.6 (16)	8.3 (3 1/4)	14.3 (5 5/8)	7.3 (2 7/8)	47.6 (18 3/4)	63.5 (25)
120	227.3 (89 1/2)	177.8 (70)	73.7 (29)	139.7 (55)	87.6 (34 1/2)	19.1 (7 1/2)	181.6 (71 1/2)	63.5 (25)	108.6 (42 3/4)
	J	K	L	M	N	P	Q	Y	Z
	116.8 (46)	6.4 (2 1/2)	50.8 (20)	45.7 (18)	3.2 (1 1/4)	5.1 (2)	4.4 (1 3/4)	62.9 (24 3/4)	52.1 (20 1/2)

**Notes:**

- 1) All units ship from the factory as a packaged, one-piece unit.
- 2) If required, systems can be shipped from the factory split for rigging into the building. This option includes installed stub kits to prevent the loss of the refrigerant charge.

## BWA-024/180

(DX Split Air Handlers For Water Cooled)

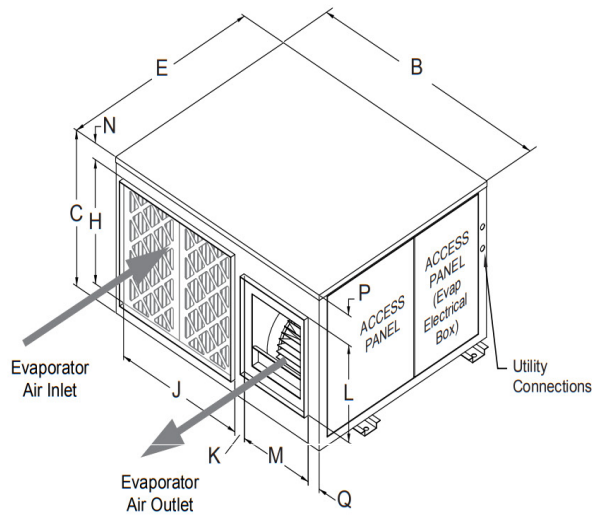

FRONT / RIGHT / TOP

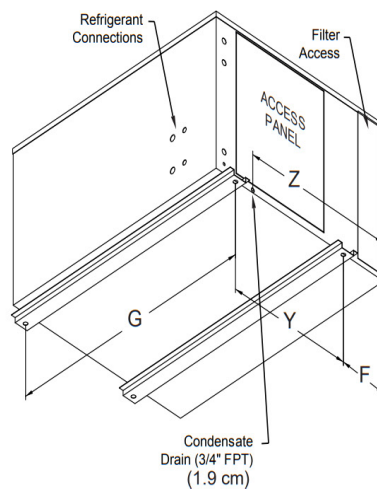

REAR / LEFT / BOTTOM

BAA & PCA- ( ) MODEL SIZE	DIMENSIONS cm (inches)							
	A	C	E	F	G	H	J	K
024, 036	109.5 (43 1/8)	55.9 (22)	62.2 (24 1/2)	14.3 (5 5/8)	113.7 (44 3/4)	45.7 (18)	50.8 (20)	7.0 (2 3/4)
	L	M	N	P	Q	Y	Z	
	35.6 (14)	30.5 (12)	3.2 (1 1/4)	5.7 (2 1/4)	14.6 (5 3/4)	42.5 (16 3/4)	61.0 (24)	
048, 060 072 & 096	B	C	E	F	G	H	J	K
	130.2 (51 1/4)	73.7 (29)	71.8 (28 1/4)	18.7 (7 3/8)	133.7 (52 5/8)	58.4 (23)	71.1 (28)	6.4 (2 1/2)
	L	M	N	P	Q	Y	Z	
	45.7 (18)	40.6 (16)	8.3 (3 1/4)	14.3 (5 5/8)	7.3 (2 7/8)	47.6 (18 3/4)	63.5 (25)	
120, 144 & 180	B	C	E	F	G	H	J	K
	177.8 (70)	73.7 (29)	87.6 (34 1/2)	19.1 (7 1/2)	181.6 (71 1/2)	63.5 (25)	116.8 (46)	6.4 (2 1/2)
	L	M	N	P	Q	Y	Z	
	50.8 (20)	45.7 (18)	3.2 (1 1/4)	5.1 (2)	4.4 (1 3/4)	62.9 (24 3/4)	52.1 (20 1/2)	

## Glycol Drycooler/Fluid Cooler

(For PGA-024/180 Glycol Cooled Systems)

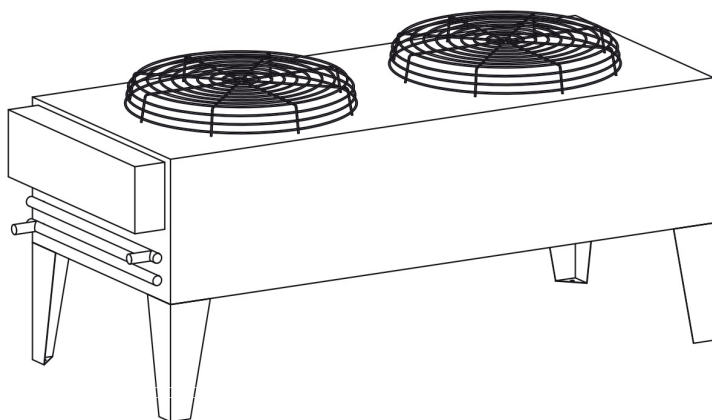

Refer to Skil-Aire Glycol Drycooler Engineering Manual for Dimensional & Performance Selection Details

## Glycol Pump Packages

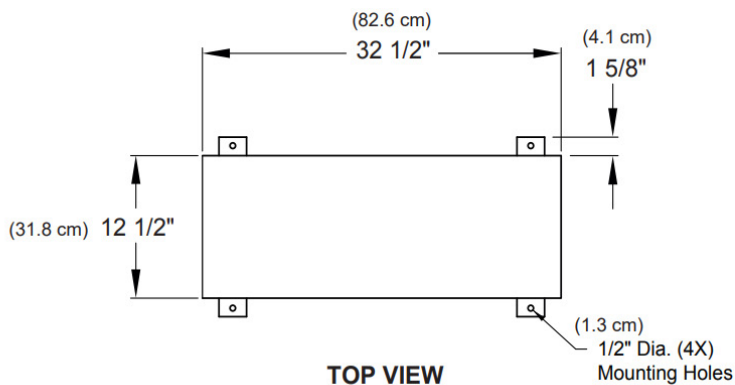

Simplex Pump Package Technical Data

Pump Model	HP	LPM (GPM)	Total Head	Power Supply (V / PH / HZ)	FLA
PP-005	1/2	18.9 (5)	70 Ft.	208-230/1/60	5.3
PP-075	3/4	37.9 (10)	70 Ft.	208-230/1/60	7.4
PP-010	1	75.7 (20)	85 Ft.	208-230/1/60	8.5
PP-015	1 1/2	151.4 (40)	88 Ft.	208-230/1/60	9.9
				208-230/3/60	6.5
				460/3/60	3.0

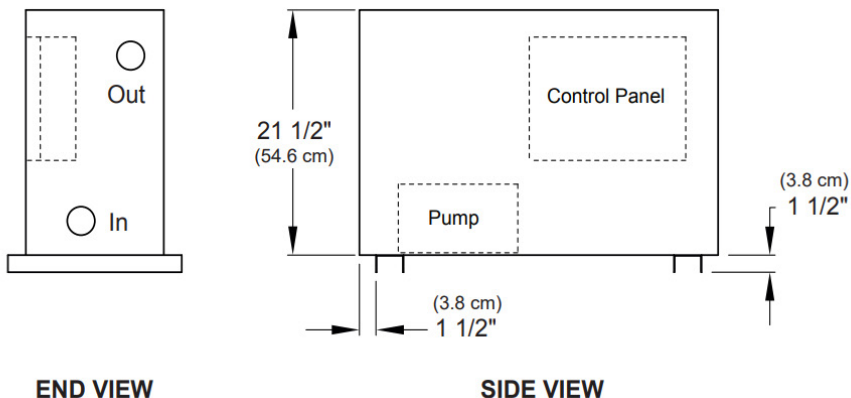

## BWA-024/180

(DX Split Air Handlers For Water Cooled)

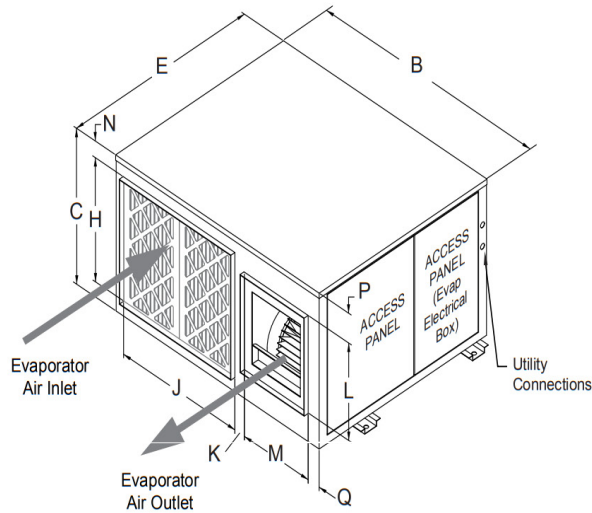

FRONT / RIGHT / TOP

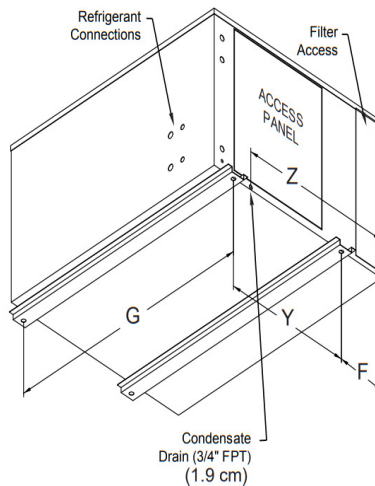

REAR / LEFT / BOTTOM

BAA & PCA- ( ) MODEL SIZE	DIMENSIONS cm (inches)							
	A	C	E	F	G	H	J	K
024, 036	109.5 (43 1/8)	55.9 (22)	62.2 (24 1/2)	14.3 (5 5/8)	113.7 (44 3/4)	45.7 (18)	50.8 (20)	7.0 (2 3/4)
	L	M	N	P	Q	Y	Z	
	35.6 (14)	30.5 (12)	3.2 (1 1/4)	5.7 (2 1/4)	14.6 (5 3/4)	42.5 (16 3/4)	61.0 (24)	
048, 060 072 & 096	B	C	E	F	G	H	J	K
	130.2 (51 1/4)	73.7 (29)	71.8 (28 1/4)	18.7 (7 3/8)	133.7 (52 5/8)	58.4 (23)	71.1 (28)	6.4 (2 1/2)
	L	M	N	P	Q	Y	Z	
	45.7 (18)	40.6 (16)	8.3 (3 1/4)	14.3 (5 5/8)	7.3 (2 7/8)	47.6 (18 3/4)	63.5 (25)	
120, 144 & 180	B	C	E	F	G	H	J	K
	177.8 (70)	73.7 (29)	87.6 (34 1/2)	19.1 (7 1/2)	181.6 (71 1/2)	63.5 (25)	116.8 (46)	6.4 (2 1/2)
	L	M	N	P	Q	Y	Z	
	50.8 (20)	45.7 (18)	3.2 (1 1/4)	5.1 (2)	4.4 (1 3/4)	62.9 (24 3/4)	52.1 (20 1/2)	